

Battery System Confirmation 电池系统确认书

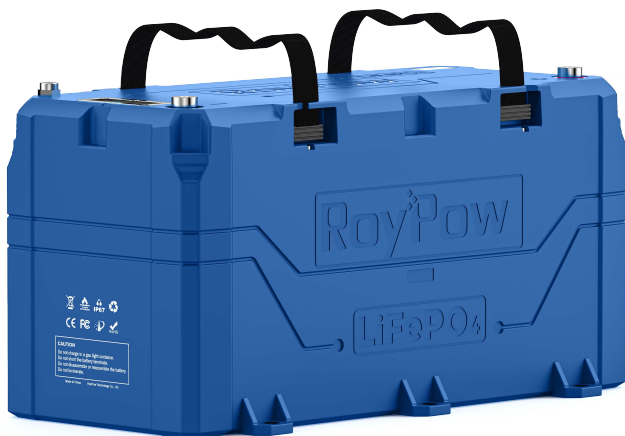

B36100H-A Battery System B36100H-A 电池系统

Document No/文件编号: RD-B36100H-A-S-01

Version/版本: A.0

Date/日期: 2024.11.8

B36100H-A Battery System

Type/类型	Parameter/参数
Product Name/产品名称	Battery System/电池系统
Product Model/产品型号	B36100H-A
Product Specification/产品规格	38.4V 100Ah 3.84kWh
Prepared by/拟制	QC. Yan
Examined by/审核	YL.Li/SJ.Zhou
Approved by/批准	-
Customer confirmation/客户确认	

HUIZHOU ROYPOW TECHNOLOGY CO., LTD.

✉ sales@roypow.com
service@roypow.com
marketing@roypow.com

📍 ROYPOW Industrial Park, No. 16, Dongsheng South Road, Chenjiang Street,
Zhongkai High-Tech District, Huizhou City, Guangdong Province, China

☎ +86 (0) 752 327 9099

🌐 www.roypow.com

1. Product Overview/产品概况

1.1. Technical specification/技术要求

Item 项目		Unit 单位	Specifications 规格	Remarks 备注
额定容量 Rated capacity		Ah	100Ah	
配置 Configuration		-	12S1P	
Operating temperature 操作温度	Charging working temperature 充电工作温度	°C	0~55	
	Discharge working temperature 放电工作温度	°C	-20~60	
Storage temperature 存储温度	Short-term (within 1 month) 短期 (1 个月内)	°C	-20~45	
	Long-term (within one year) 长期 (一年内)	°C	0~35	
Rated voltage 额定电压		V	38.4	Cell 3.2V
Maximum voltage 最大电压		V	43.8	Cell 3.65V
Minimum voltage 最小电压		V	32.4	Cell 2.7V
Standard capacity 常规容量		kWh	3.84	@ 0.5C, 25°C
Weight 重量		Kg	34±0.5	
Maximum discharge current 最大放电电流 (@30S, 25°C, SOC50%, BOL)		A	200	
Maximum charging current 最大充电电流 (@5S, 25°C, SOC 50% BOL)		A	100	
Continuous discharge current 连续放电电流 (@25°C, SOC50%, BOL)		A	100	

Continuous charging current 连续充电电流 (@25°C, SOC 50% BOL)	A	50	
Heating function 加热功能	-	Y 是	
Ingress protection IP 防护等级	-	IP67	
Whether to match our charger 是否需要匹配我司充电器	-	-	
Whether to communicate with the whole vehicle 是否与整车通讯	-	Y 是	CAN/250K

1.2. Mechanical Interface/机械界面

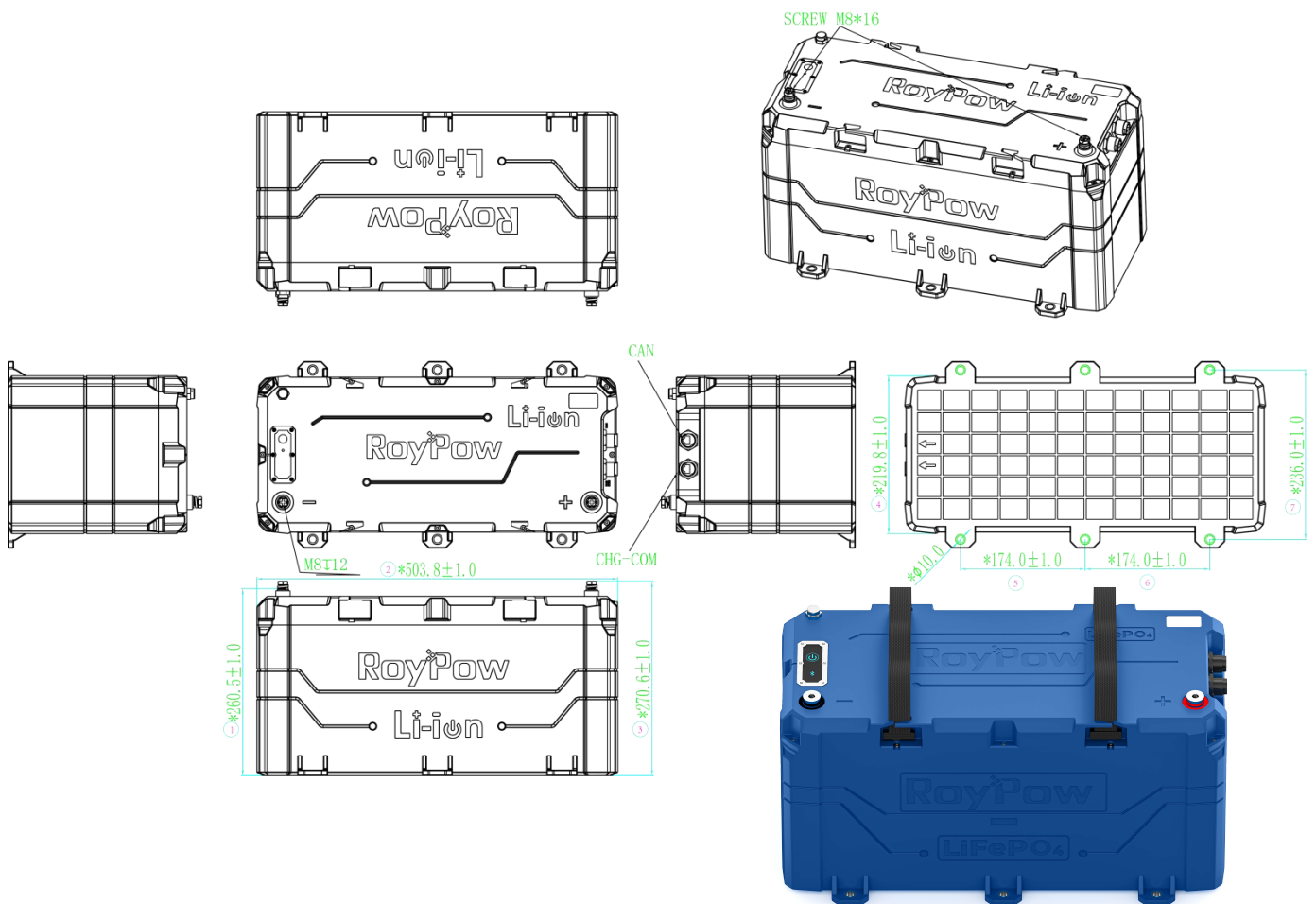

Figure 1. System Tolerance

图 1. 系统公差

Basic Dimensions/基本尺寸表

Name 名称	Size 尺寸
Size of battery system 电池系统尺寸(LxWxH)	19.8x9.3x10.6 inch (503.8x236x270.6 mm)

2. Requirements for Packaging/包装要求

2.1. Schematic Diagram of Packaging/包装示意图

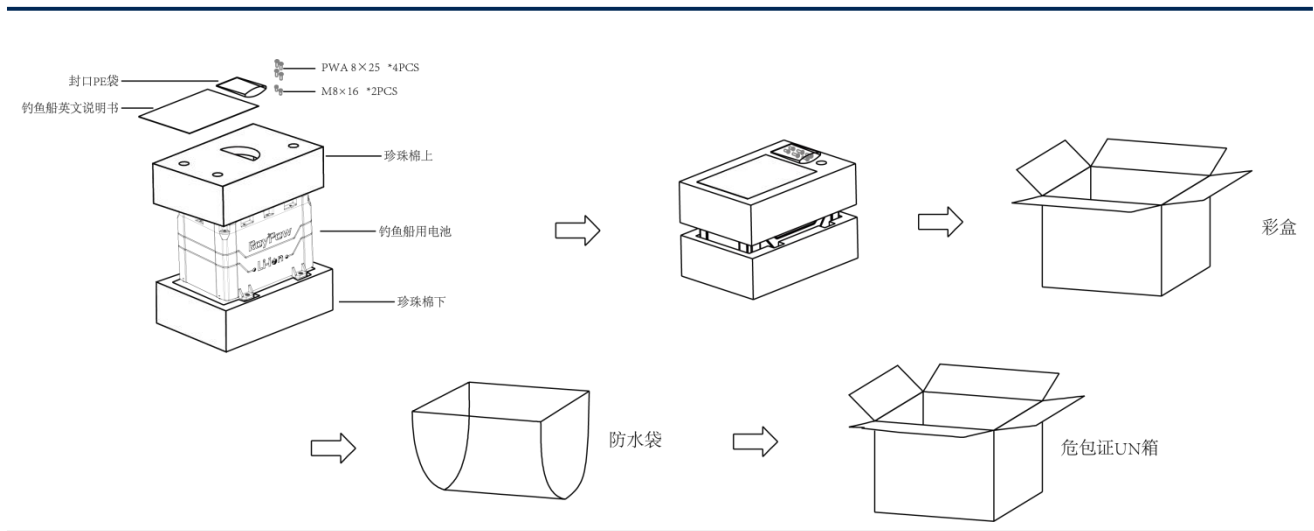

Figure 2. Schematic Diagram of Packaging

图 2. 包装示意图

2.2. Packing List/装箱清单

Part Name 产品名称	Part Number 产品编码	Product Specification 产品规格	Package Quantity 包装数量
Battery system 电池系统	B36100H-A	38.4V 100Ah 3.84kWh	1pcs